



**Holographic Pet Immune Detector
INSTALLATION INSTRUCTIONS**



**Best
Manufacturer
1999 & 2000**

**Intruder Alarm
Manufacturer
of the Year
2000 & 2001**

THANK YOU FOR VOTING TEXECOM

Ask your distributor today for the new Texecom full colour Product Guide.

Texecom
www.texe.com

QUALITY ASSURANCE



WARRANTY

10 year replacement warranty.

The 3D-PetWise is designed to detect the movement of an intruder and activate an alarm control panel. As the 3D-PetWise is not a complete alarm system, but only a part thereof, Texecom cannot accept responsibility or liability for any damages whatsoever based on a claim that the 3D-PetWise failed to function correctly. Due to our policy of continuous improvement Texecom reserves the right to change specification without prior notice. All specifications are measured at 20°C (68°F).

Document Ref: 3DPET/EU/1.0-5
© 1994 - 2004 Texecom Ltd

1 PHYSICAL

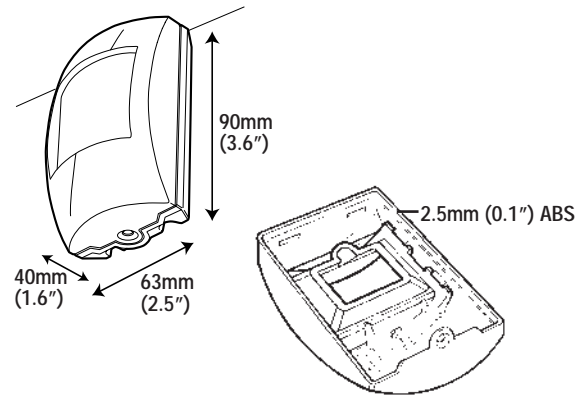

2 ENVIRONMENTAL

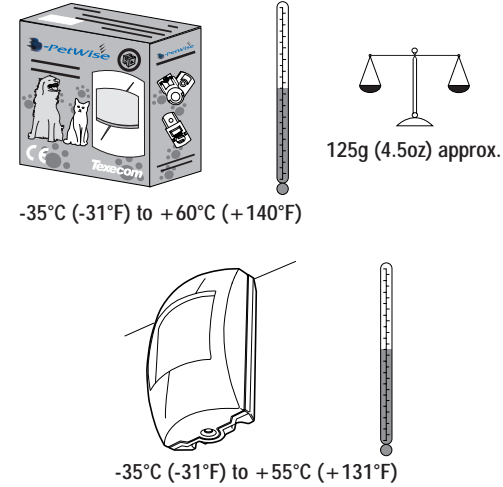

3 FALSE ALARM PROTECTION

- Design:** Noise reduction circuits with maximum ground plane. Intruder Confirmation Circuitry (ICC™).
- RF Immunity:** No false alarms at 200V/m due to digital telephone disturbances, tested to DD ENV 50204 : 1996, at 900MHz. No false alarms from 80MHz to 1GHz at 65V/m modulated, equivalent to a 1200W uniform transmitter at 3m (10ft). Complies with BS EN 61000-4-3 : 1997.
- Electrostatic Discharge:** No false alarm up to 8kV. Complies with BS EN 61000-4-2 : 1995.
- Fast Transient Immunity:** No false alarm up to ±4kV. Complies with BS EN 61000-4-4 : 1995.
- High Energy Transient Immunity:** No false alarm up to ±2kV. Complies with BS EN 61000-4-5 : 1995.
- Conducted RF Susceptibility:** No false alarms at 10Vrms. Complies with BS EN 61000-4-6 : 1996.
- Conducted Emissions:** Complies with EN 55022 Class B.
- Radiated Emissions:** Complies with EN 55022 Class B.
- EMC:** Independently certified to EN 50130-4 : 1996.
- Pulse Count:** Adjustable Adaptive Pulse Count. Internal link to select.

4

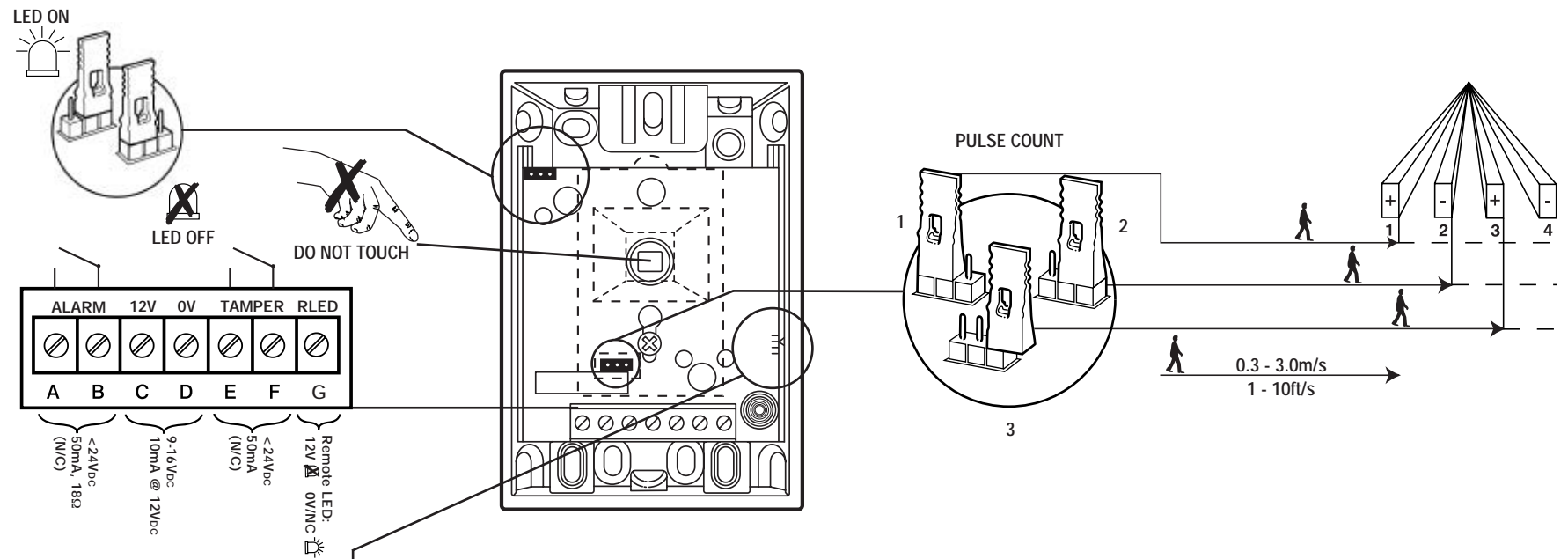

5 COVERAGE PATTERNS

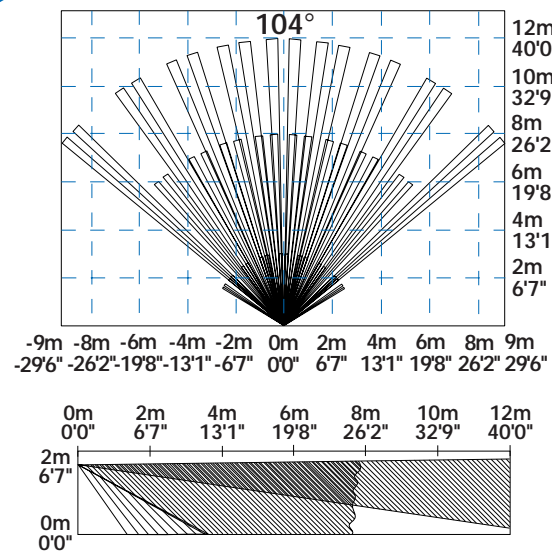

6 MOUNTING HEIGHT AND SETTINGS

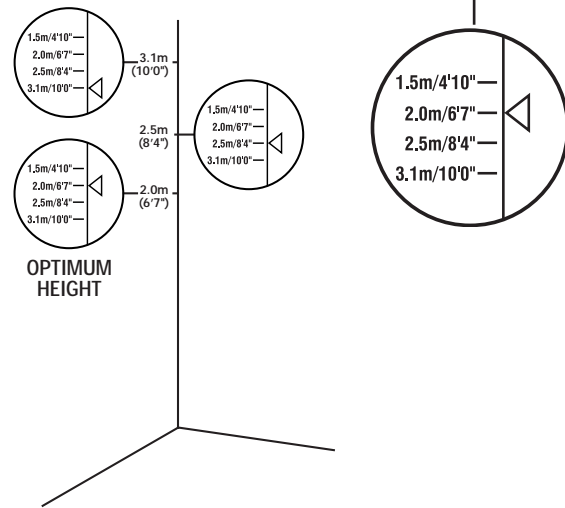

7 ENSURE PCB IS AT THE CORRECT POSITION (FOR CHOSEN MOUNTING HEIGHT)

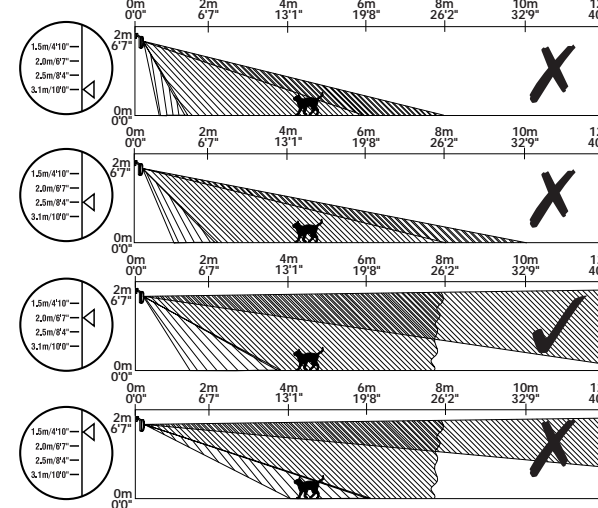

8 BEWARE OF OBSTRUCTIONS

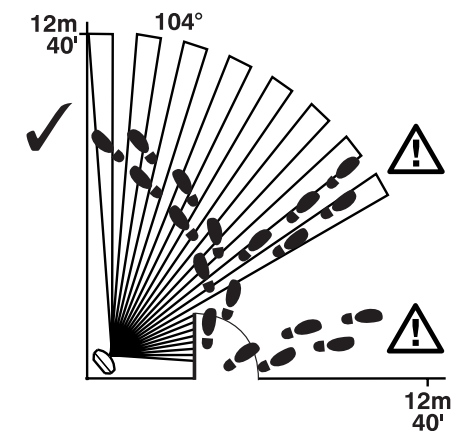

9 MOUNTING THE 3D-PETWISE
For indoor use only

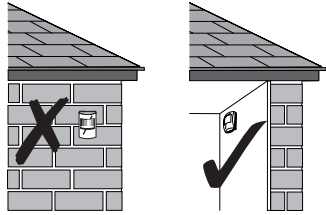

Mount on a stable surface

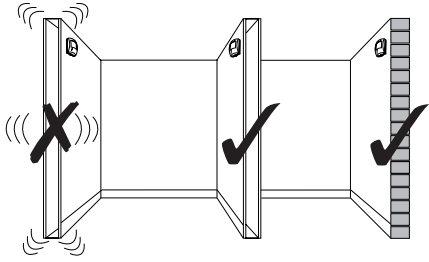

12 DO NOT ANGLE THE DETECTOR DOWNWARDS

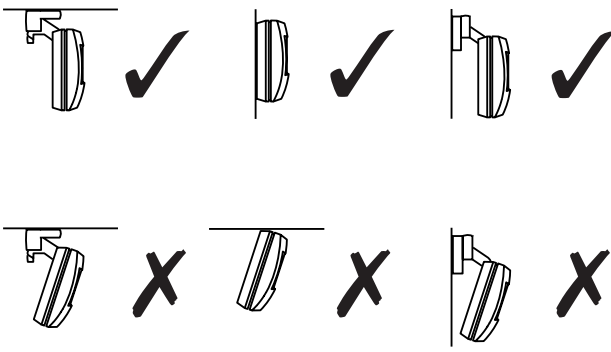

10 CHOOSING A LOCATION
Avoid common false alarm sources

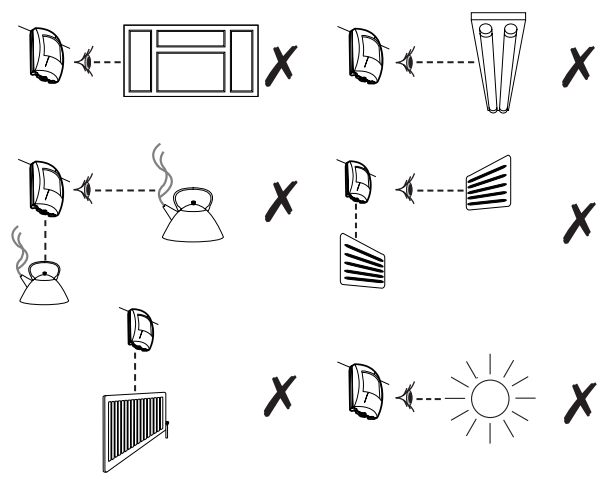

11 CHOOSING A LOCATION
A lens masking label is included to mask off problem zones

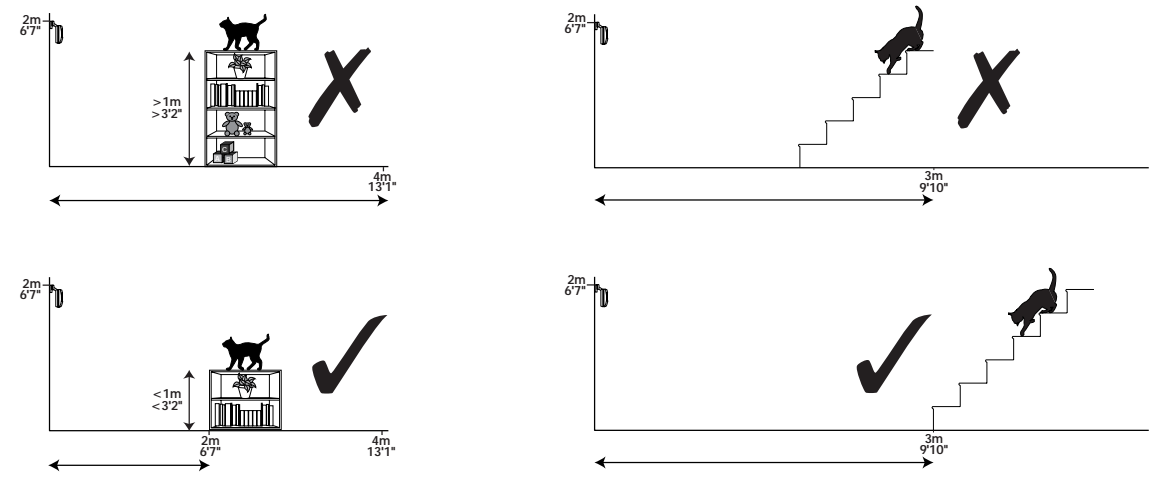

13 DO NOT RUN CABLES PARALLEL TO MAINS WIRES

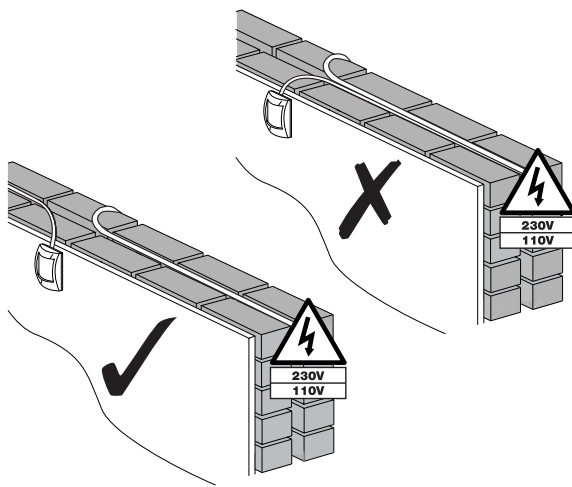

14 DETECTOR KNOCKOUTS

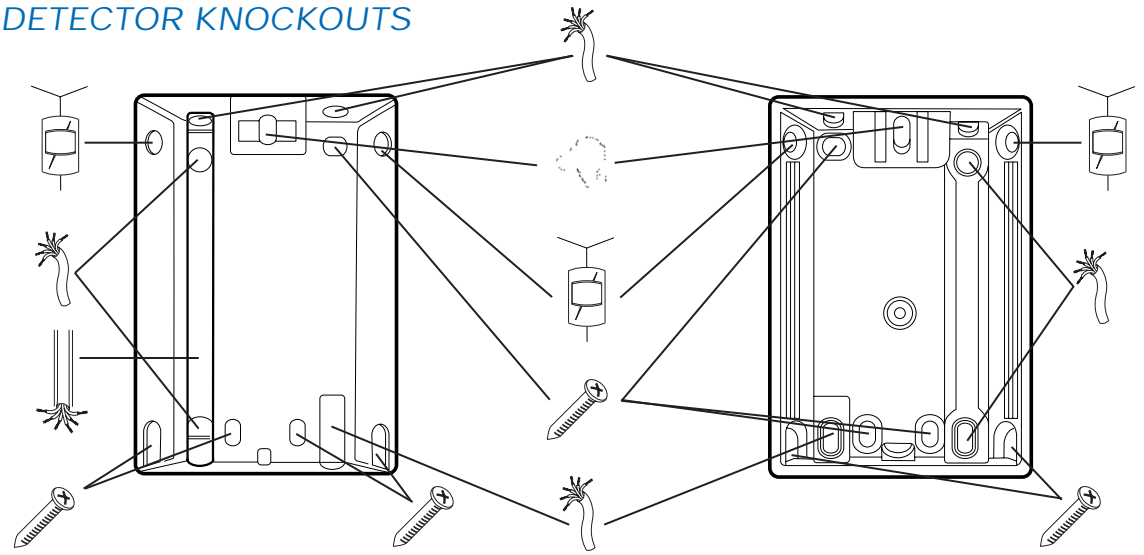

15 CEILING MOUNT BRACKET

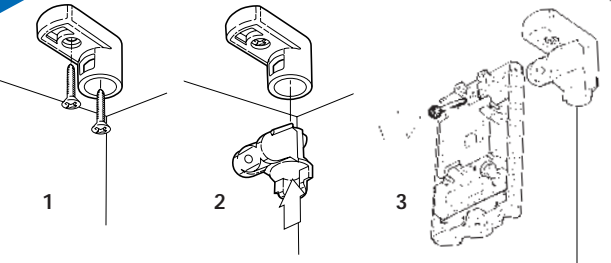

16 WALL MOUNT BRACKET

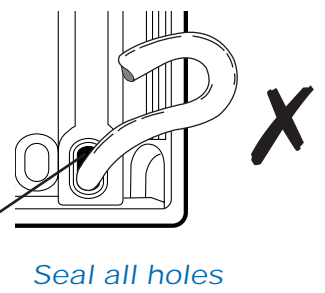
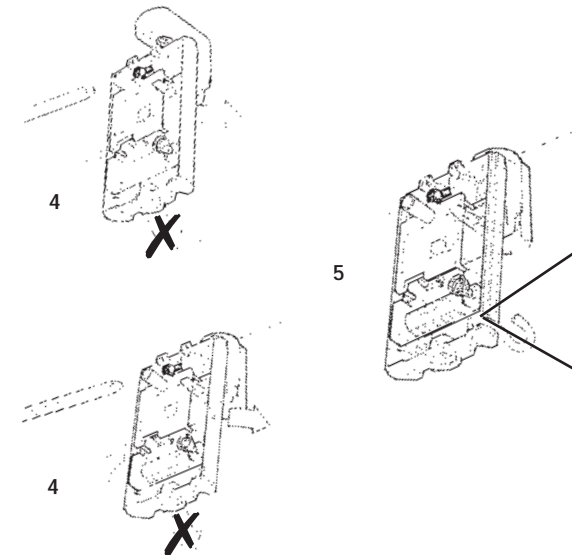
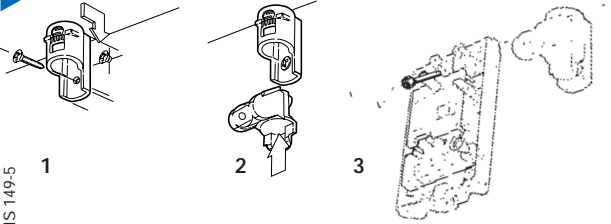

Seal all holes

17 MOUNTING WITHOUT BRACKETS

